

# EXPERIMENT 11

## AIM

To find the focal length of a convex mirror using a convex lens.

## APPARATUS AND MATERIAL REQUIRED

An optical bench with uprights for holding lens, mirror and two needles, two needles (pins), a thin convex lens, a convex mirror, index needle (may be a knitting needle or a pencil sharply pointed at both ends), a metre scale and a spirit level.

## PRINCIPLE

Fig. E 11.1 illustrates the formation of image of an object AB by a convex mirror MM' (having a small aperture) in two different situations. The image formed by a convex mirror is virtual and erect. Therefore, its focal length cannot be determined directly. However, it can be determined by introducing a convex lens in between the object and the convex mirror (Fig. E 11.2).

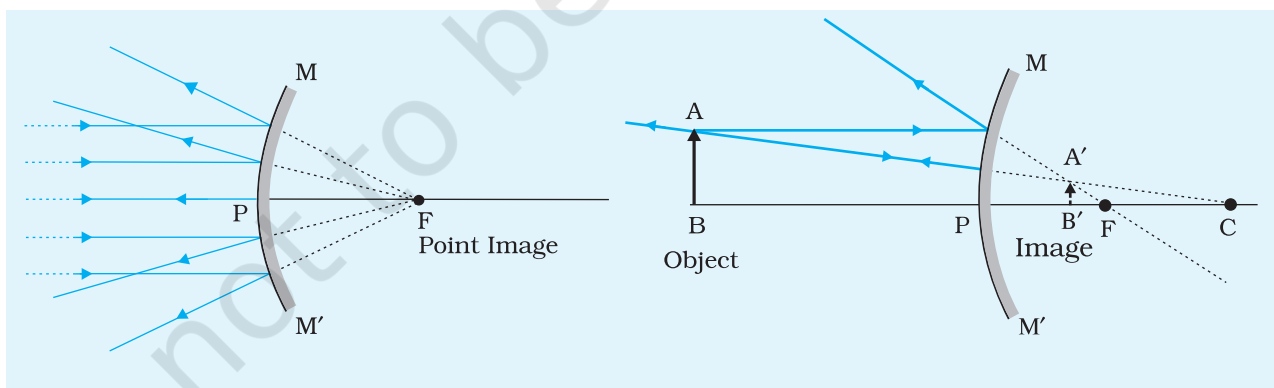

**Fig. E 11.1(a)** Object is at infinity. A highly diminished and point image is located at the focus behind the convex mirror

**Fig. E 11.1(b)** Object is in front of the mirror. A diminished virtual image is produced between the pole and focus behind the mirror

An object AB is placed at point P' in front of a thin convex lens such that its real, inverted and magnified image A'B' is formed at position

C on the other side of the lens [Fig. E 11.2(b)]. Now a convex mirror is introduced between the convex lens and point C and so adjusted that the real and inverted image  $A'B'$  coincides with the object  $AB$  at point  $P'$  [Fig. E 11.2 (a)]. This is possible if the light rays starting from the tip of the object, after passing through the lens, fall normally on the reflecting surface of the convex mirror and retrace their path. Any normal ray (perpendicular) to a spherical surface has to be along the radius of that sphere so that point C must be the centre of curvature of the convex mirror. Therefore, the distance  $PC$  is the radius of curvature  $R$  and half of it would be the focal length of the convex mirror. That is,

$$f = \frac{PC}{2} = \frac{R}{2}$$

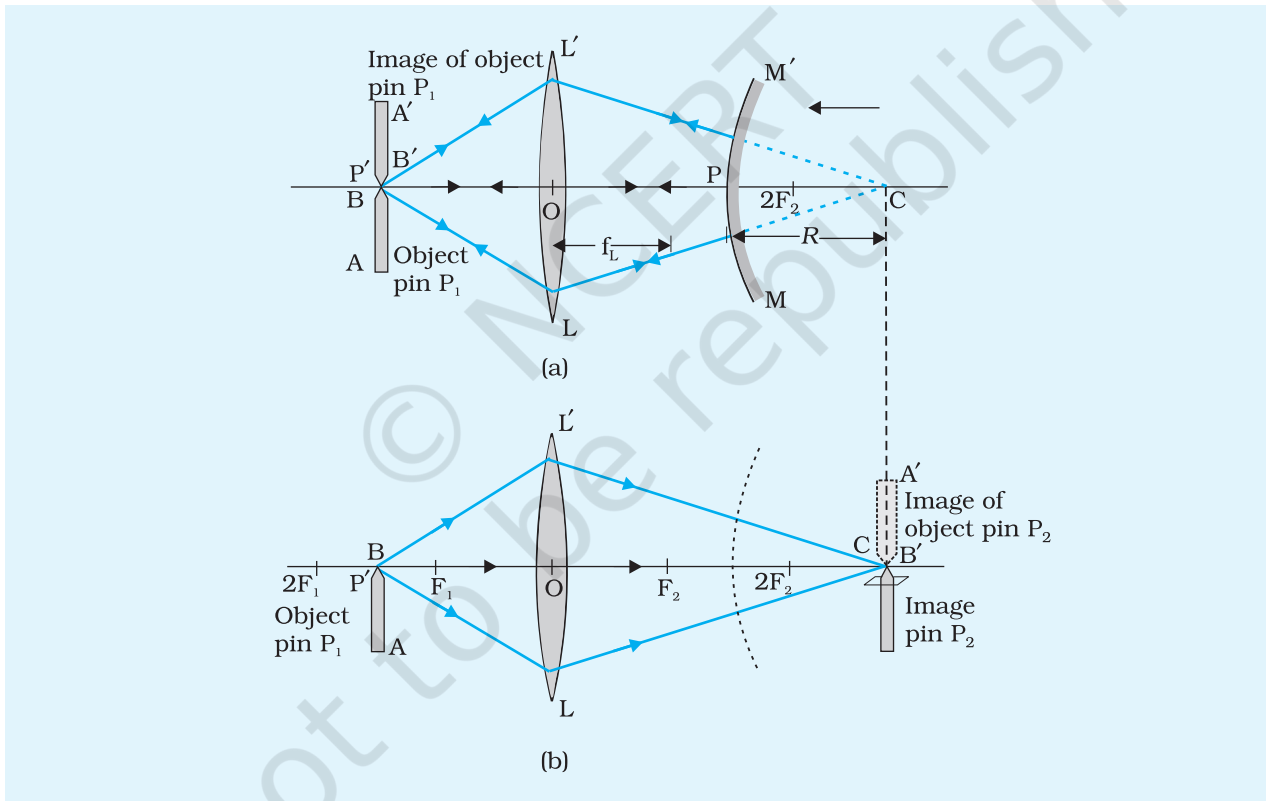

**Fig. E 11.2** Image formed by (a) convex mirror and convex lens-image  $A' B'$  coincides with the object  $A B$  at  $P'$  (b) convex lens- image is inverted and magnified

## PROCEDURE

1. In case, if the focal length of the given thin convex lens is not known then approximate value of its focal length should be estimated first.

2. Place the optical bench on a rigid table or on a platform. Using the spirit level, make it horizontal with the help of levelling screws provided at the base of the bench.
3. Place the uprights mounted with pin  $P_1$  (object pin), convex lens  $LL'$ , and convex mirror  $MM'$  on the horizontal optical bench [Fig. E 11.2(a)].
4. Check that the lens, mirror, and pin  $P_1$  are vertically placed on the optical bench. Also verify that the tip of the pin, optical centre  $O$  of the convex lens  $LL'$ , and pole  $P'$  of the convex mirror  $MM'$  lie on the same horizontal straight line, parallel to the optical bench.
5. Determine the index correction between upright holding of the convex mirror and image pin respectively, using an index needle.
6. Place the object pin  $P_1$  from the convex lens  $LL'$  at a distance slightly greater than the focal length of the lens.
7. Adjust the position of the convex mirror  $MM'$  till the light rays reflected back from the mirror pass through the lens and form a real and inverted image coinciding with the object pin  $P_1$ , as shown in Fig. E 11.2 (a). This occurs when the rays starting from the tip of pin  $P_1$ , after passing through the lens strike the mirror normally and are reflected back along their original paths. Remove the parallax between the image and object pins.
8. Read the position of uprights holding the object pin  $P_1$ , convex lens  $LL'$ , and convex mirror  $MM'$  and record the observations in the observation table.
9. Remove the convex mirror from its upright and fix image pin  $P_2$  on it. Adjust the height of pin such that the tip of it also lies on the principal axis of the lens. That is, the tips of the pins  $P_1$  and  $P_2$  and the optical centre  $O$  of the convex lens, all lie on a straight horizontal line parallel to the length of the optical bench.
10. You may put a small piece of paper on image pin  $P_2$  to differentiate it from the object pin  $P_1$ .
11. Using the method of parallax and without changing the position of lens  $LL'$  and object pin  $P_1$ , adjust the position of image pin  $P_2$  on the other side of the lens so that it coincides with the real and inverted image of the object pin  $P_1$  formed by the convex lens [Fig. E 11.2(b)]. Note the position of the image pin.
12. Repeat the experiment by changing the separation between the pin  $P_1$  and lens  $LL'$  and the mirror  $MM'$ . In this manner, take five sets of observations.

## OBSERVATIONS

1. Focal length of the convex lens,  $f$  (estimated/given) = ... cm
2. Actual length of the index needle,  $l$  = ... cm
3. Observed length of the index needle  $l'$   
= Position of mirror upright – position of pin upright on the scale  
= ... cm
4. Index correction,  $e$  = Actual length – observed length ( $l - l'$ ) = ... cm

**Table E 11.1: Determination of radius of curvature of convex mirror,  $R$**

Sl. No.	Upright position of				Observed $R' = c - d$ (cm)	Corrected $R$ Observed $R' + e$ (cm)	Focal length $f$ (cm)	$\Delta f$ (cm)
	Object pin $P_1$ $a$ (cm)	Convex lens $LL'$ $b$ (cm)	Convex mirror $MM'$ $c$ (cm)	Image pin $P_2$ $d$ (cm)				
1								
2								
...								
5								
					Mean			

## CALCULATIONS

Calculate the mean value of radius of curvature of the convex mirror,  $R$ , and determine its focal length using the following relation

$$f = \frac{R}{2} = \dots \text{ cm}$$

### Error

$$f = \frac{R' + l}{2} = \frac{(c - d) + (l - l')}{2}$$

$$\frac{\Delta f}{f} = \frac{\Delta c}{c} + \frac{\Delta d}{d} + \frac{\Delta l}{l} + \frac{\Delta l'}{l'}$$

when  $\Delta c$ ,  $\Delta d$ ,  $\Delta l$  and  $\Delta l'$  are the least counts of the measuring instruments. Maximum of the five values of  $\Delta f$  is to be reported with the result as the experimental error.

## RESULT

The focal length of the given convex mirror is  $(f \pm \Delta f) \dots \pm \dots$  cm.

Here  $f$  is mean value of the focal length.

## PRECAUTIONS

1. The uprights supporting the pins, lens and mirror must be rigid and mounted vertically.
2. The apertures of the given convex lens and convex mirror should be small, otherwise the image formed will be distorted.
3. Eye should be placed at a distance of about 25 cm or more from the image pin.
4. Optical bench should be horizontal. The tips of pins, centre of convex lens and pole of the mirror should be at the same horizontal level.

## SOURCES OF ERROR

1. The tip of the inverted image of the object pin should just touch the tip of the image pin and must not overlap. This should be ensured while removing the parallax.
2. Personal eye defects may make removal of parallax tedious.
3. The convex mirror should preferably be front-coated. Otherwise multiple reflections may take place.

## DISCUSSION

It may not be possible to perform this experiment with just any convex lens. The focal length of the lens used in this experiment should neither be too small nor too large. Why?

## SELF ASSESSMENT

1. If focal length of the concave mirror is determined, by using convex lenses of different focal lengths, do you expect any change in the result? If yes, what type of change? If not, why not?

2. How will the result change if a convex lens of different refractive indices were used?
3. If the convex lens selected for the experiment has focal length less than that of the convex mirror, how would this selection limit the experiment?

**SUGGESTED ADDITIONAL EXPERIMENTS/ACTIVITIES**

1. Repeat the experiment by using convex lenses of different focal lengths. Compare and analyse the results.
2. Repeat the experiment by using convex mirrors of different focal lengths with the help of the same convex lens. Discuss the results.

© NCERT  
not to be republished

# EXPERIMENT 12

## AIM

To find the focal length of a concave lens with the help of a convex lens.

## APPARATUS AND MATERIAL REQUIRED

An optical bench with uprights for holding the lenses and two needles, a thin concave lens, a convex lens of focal length ( $\sim 15$  cm) smaller than that of the concave lens, index needle (may be a knitting needle), a metre scale and a spirit level.

## PRINCIPLE

Figs. E 12.1 (a),(b),(c) and (d) illustrate the formation of image  $A'B'$  of an object  $AB$  by a concave lens. It is clear that the image formed by a

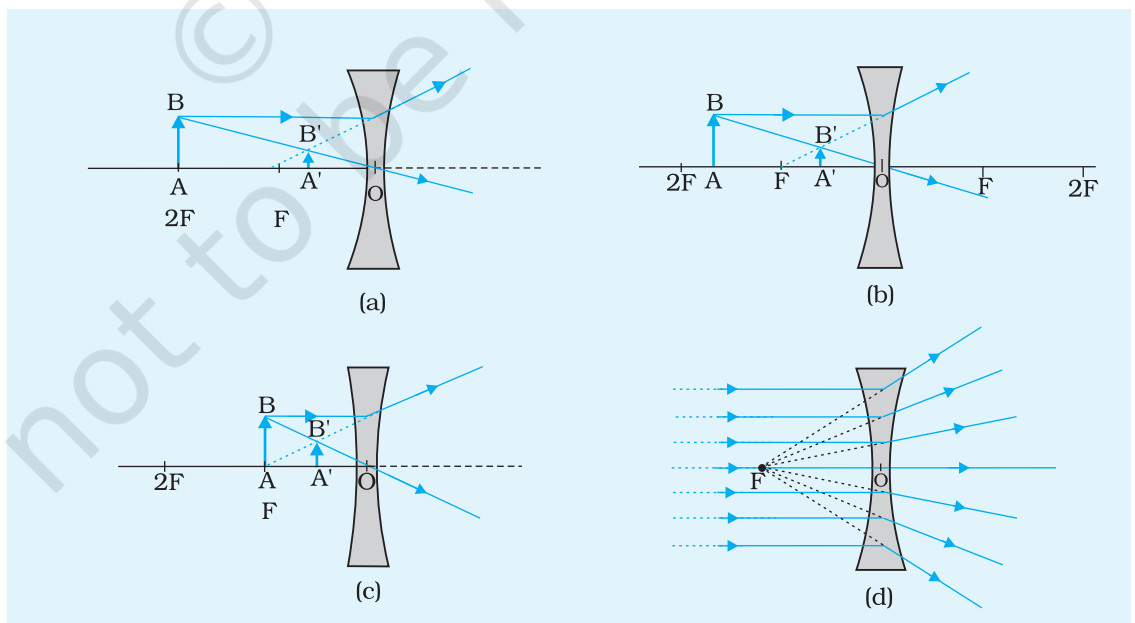

**Fig. E 12.1 (a),(b),(c), (d)** The images formed by a concave lens for different object positions

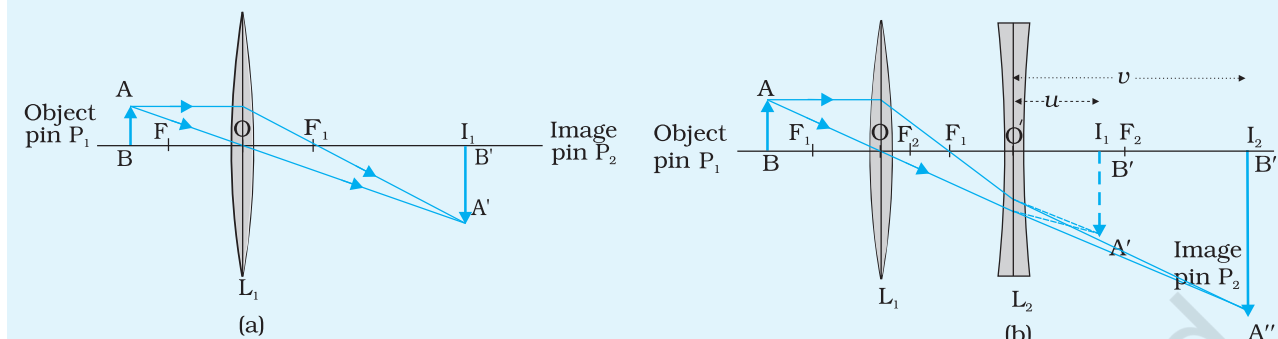

**Fig. E 12.2** Formation of image (a) by a convex lens; and (b) by a combination of convex lens and concave lens

concave lens is always virtual and erect in these cases. Therefore, its focal length cannot be determined directly. However, it can be determined indirectly by introducing a convex lens in between the object and the concave lens and producing a real image as illustrated in Fig. E12.2.

A convex lens  $L_1$  converges the light rays starting from the object  $AB$  to form a real and inverted image  $A'B'$  at position  $I_1$  [Fig. E 12.2(a)]. If a concave diverging lens  $L_2$  is inserted between the lens  $L_1$  and point  $I_1$  as shown in Fig. E 12.2 (b), for concave lens  $L_2$  image  $A'B'$  behaves as virtual object. A real and inverted image  $A''B''$  is formed at point  $I_2$  by the diverging lens  $L_2$ . Thus, for the concave lens  $L_2$  the distances  $O'I_1$  and  $O'I_2$  would be the distances  $u$  and  $v$ , respectively. It is important to note that the focal length of convex lens  $L_1$  must be smaller than the focal length of the concave lens  $L_2$ . The second image  $A''B''$  is formed only when the distance between lens  $L_2$  and first image  $A'B'$  is less than the focal length of  $L_2$ .

The focal length of the concave lens  $L_2$  can be calculated from the relation

$$\frac{1}{f} = \frac{1}{v} - \frac{1}{u} \quad \text{or} \quad f = \frac{uv}{u-v} \quad \text{(E 12.1)}$$

Here for the concave lens both distances  $u$  and  $v$  are positive and since  $u$  will be found to be less than  $v$ ,  $f$  will always be negative.

## PROCEDURE

1. In case, if the focal length of the given thin convex lens is not known then rough value of its focal length ( $f_1$ ) should be estimated first to ensure that its focal length is less than that of the concave lens.



2. Place the optical bench on a rigid platform and using the spirit level, make it horizontal with the help of levelling screws provided at the base of the bench.
3. Place the uprights mounted with pin  $P_1$  (object pin), convex lens  $L_1$ , and another pin  $P_2$  (image pin) on the optical bench. You may put a small piece of paper on image pin  $P_2$  to differentiate it from the image of object pin  $P_1$  [Fig. E 12.2(a)].
4. Check the collinearity of the tip of pin  $P_1$ , optical centre  $O$  of convex lens  $L_1$ , and the tip of image pin  $P_2$  along a horizontal straight line which is parallel to the length of the optical bench. In this condition the planes of lens and both the pins would be perpendicular to the axis of the lens.
5. For the determination of the index correction, bring a mounted pin close to the concave lens  $L_2$ . Adjust the index needle (a sharp-edged knitting needle would also serve the purpose) horizontally such that its one end touches one of the curved surfaces of the lens and the other end touches the tip of the pin. Note the positions of the two uprights on the scale provided on the optical bench. The difference of the two would give the *observed length* of the index needle. The *actual length* between the tip of the pin and optical centre  $O'$  of the lens  $L_2$  would be length of the index needle (as measured by a scale) plus half of the thickness of the lens at its optical centre. The difference of the two lengths is the index correction.  
  
(If the concave lens is thin at the centre, its thickness at the centre can be ignored).
6. Separate the object pin  $P_1$  from the convex lens by a distance slightly greater than the focal length  $f_L$  of the lens.
7. Locate its real and inverted image at point  $I_1$  on the other side of the lens by removing the parallax between the image pin  $P_2$  and image of the object pin  $P_1$  [Fig. E 12.3(a)].
8. Read the positions of the uprights holding the object pin  $P_1$ , convex lens  $L_1$ , and image pin  $P_2$  (i.e. point  $I_1$ ). Record these observations in Table E 12.1.
9. From now on, do not change the position of the convex lens  $L_1$  and the position of the object pin  $P_1$ . Insert the concave lens  $L_2$  in between the convex lens  $L_1$  and image pin  $P_2$ . Now the image of object pin will shift further from the convex lens  $L_1$  to a point  $I_2$  (say). Adjust the position of the concave lens so that the point  $I_2$  is sufficiently away from the point  $I_1$ .
10. In case the image formed by the combination of convex and concave lenses is not distinctly visible, try to see it on moving the concave lens nearer to the point  $I_1$  and to locate the image by using a pencil

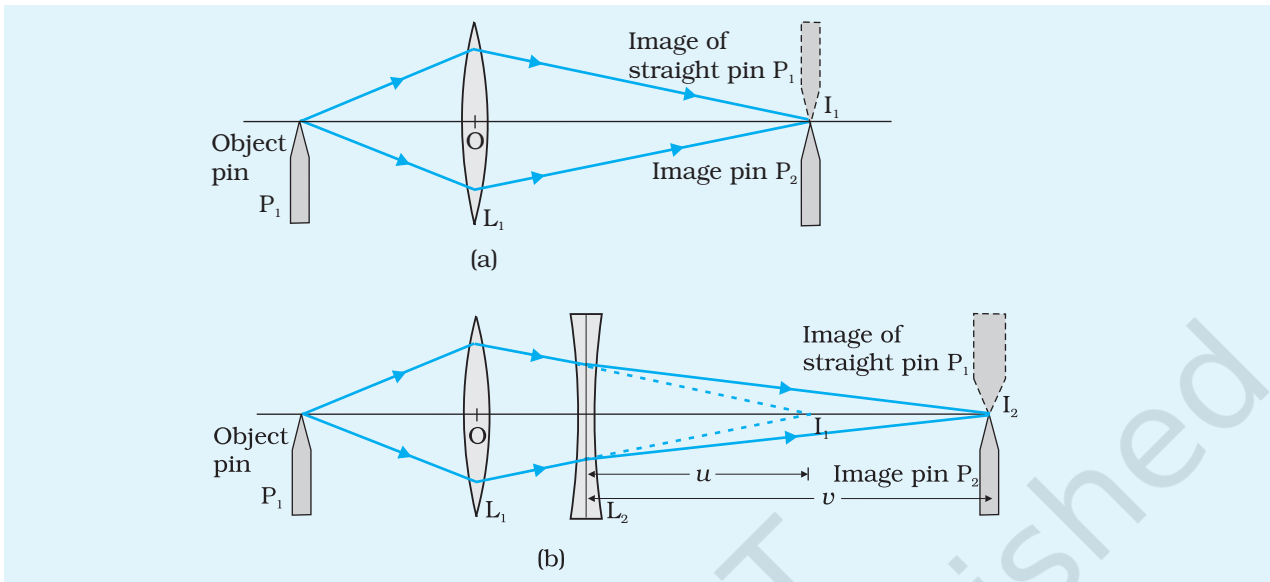

**Fig. E 12.3** Focal length of concave lens with the help of convex lens

held in hand, and keeping the image pin  $P_2$  at point  $I_1$  as a guide to decide which way to shift the concave lens  $L_2$ . After having seen the clear image at point  $I_2$  and ensured that it lies within the range of the optical bench, move image pin  $P_2$  to locate the image (or point  $I_2$ ) more accurately using the method of parallax [Fig. E 12.3(b)]. Since the image forming at  $I_2$  is quite enlarged, it can be blurred.

11. Note the position of uprights holding the concave lens and image pin  $P_2$ , i.e., point  $I_2$ . Note the readings in the Observation Table.
12. Change the position of upright holding the object pin  $P_1$  and repeat the steps 6 to 11. Take five sets of observations.

## OBSERVATIONS

1. Focal length of the convex lens,  $f_L = \dots$  cm
2. Length of the index needle as measured by the scale,  $s = \dots$  cm
3. Thickness of the thin concave lens (given) at its optical centre,  $t = \dots$  cm
4. Actual length between the optical centre  $O$  of the lens and tip of the pin,  $l = s + t/2 = \dots$  cm
5. Observed length of the index needle,  $l'$ 
  - = Distance between the pole of the lens and tip of the pin
  - = Position of lens upright - position of pin upright on the scale
  - =  $\dots$  cm

**Table E 12.1: Determination of  $u$ ,  $v$ , and  $f$  of concave lens**

Sl. No.	Position of										
	Object pin upright $P_1$ , $a$ (cm)	Convex lens $L_1$ upright, $b$ (cm)	Image formed by $L_1$ , point $I_1$ , $c$ (cm)	Concave lens $L_2$ upright, $d$ (cm)	Image formed by $L_1$ and $L_2$ , point $I_2$ , $g$ (cm)	Observed $u$ = $c - d$ (cm)	Observed $v$ = $g - d$ (cm)	Corrected $u$ = Observed $u + e$ (cm)	Corrected $v$ = Observed $v + e$ (cm)	$f = uv/(u - v)$ (cm)	$\Delta f$ (cm)
1											
2											
-											
5											
									Mean		

6. Index correction,  $e = l - l' = \dots$  cm

## CALCULATIONS

Find the focal length of the concave lens using the formula  $f = \frac{uv}{u - v}$

### Error

$$\frac{1}{f} = \frac{1}{v} - \frac{1}{u}$$

$$\frac{\Delta f}{f^2} = \frac{\Delta v}{v^2} + \frac{\Delta u}{u^2}$$

$$\Delta f = f^2 \left[ \frac{\Delta v}{v^2} + \frac{\Delta u}{u^2} \right]$$

where  $\Delta u$ ,  $\Delta v$  represent least counts of the measuring scale. Values of  $u$ ,  $v$ ,  $f$  are to be taken from the Observation Table. Maximum of the five values of the error  $\Delta f$  is to be reported with the result as error.

## RESULT

The focal length of the given concave lens is  $(f \pm \Delta f) = \dots \pm \dots \text{cm}$ .

## PRECAUTIONS

Here  $f$  is mean value of the focal length.

1. The concave lens must be placed near the convex lens. In fact, the second image  $I_2$  is formed only when the distance between concave lens  $L_2$  and first image  $I_1$  (which acts as virtual object for the concave lens) is less than the focal length of the concave lens.
2. Since the image formed at  $I_2$  is quite enlarged, it can be blurred. Therefore, it would be preferable to use a thin and sharp object pin and shine it with light using a lighted electric bulb.
3. The convex lens and the pin  $P_1$  must not be disturbed during the second part of the experiment.
4. A diminished, real and inverted image of the image pin  $P_2$  might also be formed by the light rays reflecting from the concave surface of the lens  $L_2$ . It should not be confused with the bold and bright image formed by the combination of convex and concave lenses.
5. Index correction/ bench correction for  $u$  and  $v$  should be made.

## SOURCES OF ERROR

1. If tip of object pin and optical centre of the lens are not aligned properly (if not brought at the same horizontal level), image tip and image of object pin tip will not touch each other. There may be some gap between the two or there could be overlap between the two. In such situations, there can be error in removing parallax and it will lead to errors in the result.
2. For greater accuracy we should use sharply pointed object pin.

## DISCUSSION

1. As concave lens diverges the rays, the image formed by a concave lens alone will not be real and cannot be taken on a screen. To converge these diverging rays to form a real image, convex lens is used.
2. Diverging rays from concave lens can be made to fall normally on a concave mirror to get the real image formed at the point where object is placed. Hence, the focal length of the concave lens can be found by using a concave mirror also.

3. Since the image  $I_2$  is quite enlarged, it can get blurred by chromatic aberration of the two lenses. Thus it is better to put a screen behind object pin  $P_1$  and thus do the entire experiment with one colour of light instead of with white light. For the same reason, pin  $P_1$  should be quite thin and sharp compared to pin  $P_2$ .

## SELF ASSESSMENT

1. In this experimental setup the combination of concave lens and convex lens separated by a distance  $d$  behaves as a single lens of focal length  $F$ . Check the relation  $\frac{1}{F} = \frac{1}{f_1} + \frac{1}{f_2} - \frac{d}{f_1 f_2}$  for any one of the observations.
2. Calculate  $f$  by interchanging the value of  $u$  and  $v$  and compare it with the experimentally determined value of  $f$ .

### SUGGESTED ADDITIONAL EXPERIMENTS/ACTIVITIES

1. Plot a graph of  $uv$  against  $u-v$  with  $uv$  on y-axis and  $u-v$  on x-axis. Determine  $f$  from the slope of the graph.
2. Repeat the experiment by using concave and convex lenses of different focal lengths, compare and analyse the results.

# EXPERIMENT 13

## AIM

To determine the angle of minimum deviation for a given glass prism by plotting a graph between the angle of incidence and the angle of deviation.

## APPARATUS AND MATERIAL REQUIRED

Drawing board, triangular glass prism, metre scale, alpins, cellotape/drawing pins, graph paper, protractor, white paper sheets.

## PRINCIPLE

A triangular prism has three rectangular lateral surfaces and two triangular bases. The line along which any two faces (refracting surfaces) of the prism meet is the refracting edge of the prism and the angle between them is the angle of the prism. For this experiment, it is convenient to place the prism with its rectangular surfaces vertical. The principal section ABC of the prism is obtained by a horizontal plane perpendicular to the refracting edge (Fig. E 13.1).

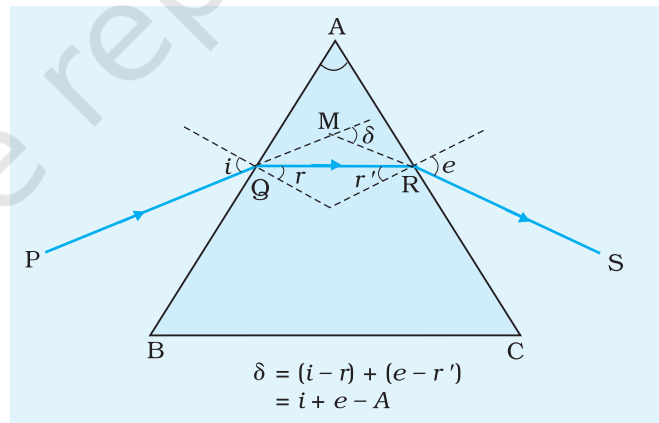

**Fig. E 13.1** Refraction of light through a glass prism

A ray of light PQ (from air to glass) incident on the first face AB at an angle  $i$  is refracted at an angle  $r$  along QR and finally, emerges along RS. The dotted lines in the figure represent the normal to the surfaces. The angle of incidence (from glass to air) at the second face AC is  $r'$  and the angle of refraction (or emergence) is  $e$ . The angle between the direction of incident ray PQ (produced forward) and the direction of emergent ray RS (produced backward) is the angle of deviation  $\delta$ .

(E 13.1)

From geometrical considerations we have

$$r + r' = A$$

(E 13.2)

$$\delta = (i - r) + (e - r') = i + e - A$$

At the position of the prism for minimum deviation  $\delta_m$ , the light ray passes through the prism symmetrically, i.e. parallel to the base so that when

$$\delta = \delta_m, i = e \text{ which implies } r = r'.$$

The advantage of putting the prism in minimum deviation position is that the image is brightest in this position.

## PROCEDURE

1. Fix a white sheet of paper on a drawing board with the help of cellotape or drawing pins.
2. Draw a straight line XY, using a sharp pencil nearly in the middle and parallel to the length of the paper.
3. Mark points  $O_1, O_2, O_3, \dots$  on the straight line XY at suitable distances of about 8 to 10 cm and draw normals  $N_1 O_1, N_2 O_2, N_3 O_3, \dots$  on these points (Fig. E 13.2).

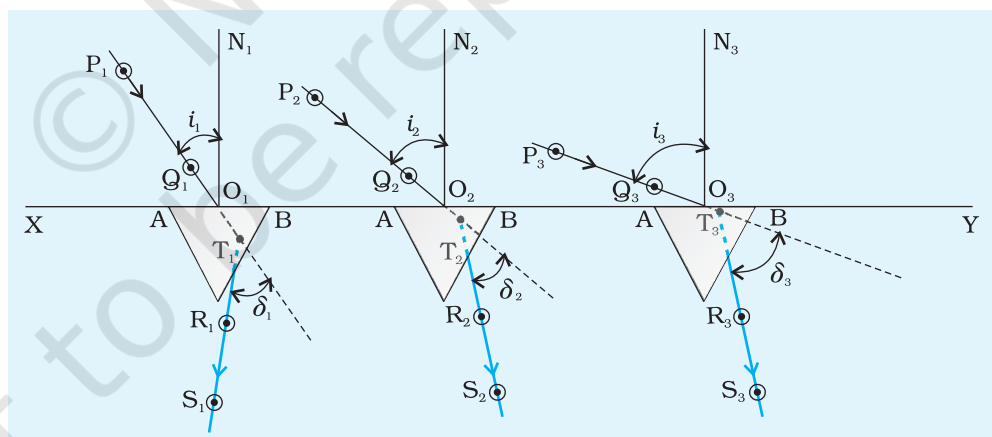

**Fig. E 13.2** Refraction of light through a glass prism for various angles of incidence

4. Draw straight lines,  $P_1 O_1, P_2 O_2, P_3 O_3, \dots$  corresponding to the incident rays making angles of incidence at  $35^\circ, 40^\circ, 45^\circ, 50^\circ, \dots 60^\circ$  respectively with the normals, using a protractor. Write the values of the angles  $\angle P_1 O_1 N_1, \angle P_2 O_2 N_2, \angle P_3 O_3 N_3, \dots$  on the white paper sheet ( Fig. E 13.2).
5. Place the prism with its refracting face AB on the line XY with point  $O_1$  in the middle of AB as shown in the figure. Draw the boundary of the prism with a sharp pencil.

6. Fix two alpins  $P_1$  and  $Q_1$  with sharp tips vertically about 10 cm apart, on the incident ray line  $P_1 Q_1$  such that pin  $Q_1$  is close to point  $O_1$ . Close one eye (say left) and looking through the prism, bring your right eye in line with the images of the pins  $P_1$  and  $Q_1$ . Fix alpins  $R_1$  and  $S_1$  about 10 cm apart vertically on the white paper sheet with their tips in line with the tips of the images of pins  $P_1$  and  $Q_1$ . In this way pins  $R_1$  and  $S_1$  will become collinear, with the images of pins  $P_1$  and  $Q_1$ .
7. Remove the pins  $R_1$  and  $S_1$  and encircle their pin pricks on the white paper sheet with the help of a sharp pencil. Remove the pins  $P_1$  and  $Q_1$  and encircle their pin pricks also.
8. Join the points ( or pin pricks)  $R_1$  and  $S_1$  with the help of a sharp pencil and scale, to obtain the emergent ray  $R_1 S_1$ . Produce it backwards to meet the incident ray  $P_1 Q_1$  (produced forward) at  $T_1$ . Draw arrowheads on  $P_1 Q_1$  and  $R_1 S_1$  to show the direction of the rays.
9. Measure the angle of deviation  $\delta_1$  and the angle BAC (angle A) of the prism (Fig. E 13.1) with a protractor and write the values of these angles indicated in the diagram.
10. Repeat steps 5 to 9 for different values of angle of incidence ( $40^\circ$ ,  $45^\circ$ ,  $50^\circ$ ...) and measure the corresponding angles of deviation  $\delta_2$ ,  $\delta_3$ ... with the protractor, and indicate them in the respective diagrams.
11. Record observations in tabular form with proper units and significant figures.

## OBSERVATIONS

Least count of the protractor = ...(degree)

Angle of the prism,  $A = \dots$ (degree)

**Table E 13.1: Measuring the angle of incidence,  $i$  and angle of deviation  $\delta$  for a prism**

Sl. No.	Angle of incidence, $i$ (degrees)	Angle of deviation, $\delta$ (degrees)
1		
2		
3		
--		
10		



*Plotting the graph between  $i$  and  $\delta$  for the prism*

Take angle of incidence  $i$  along x-axis and angle of deviation  $\delta$  along y-axis, using the observed values from Table E 13.1. Choose suitable scales on these axes and plot a graph between  $i$  and  $\delta$ . Take care that you draw a free hand smooth curve passing practically through all the plotted points on the graph (Fig. E 13.3).

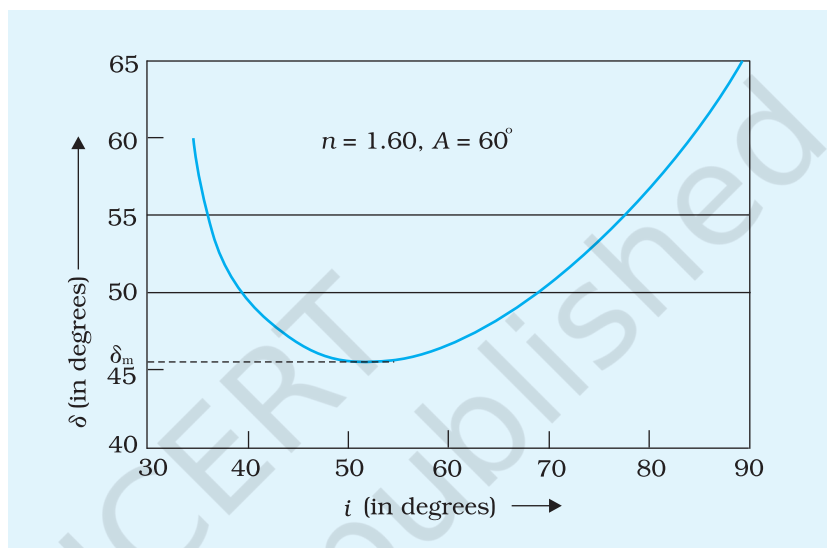

**Fig. E 13.3** Graph between angle of incidence and angle of deviation

## CALCULATIONS

Draw tangent on the lowest point of the graph parallel to x-axis, read the angle of minimum deviation  $\delta_m$  on the y-axis of the graph. Express the result with proper significant figures.

## RESULT

Angle of minimum deviation,  $\delta_m = \dots \pm \dots$  degree

## PRECAUTIONS

1. Alpins should be fixed vertically to the plane of paper.
2. Distance PQ and RS should be about 10 cm in order to locate incident and emergent rays with greater accuracy.
3. Same angle of prism should be used for all observations.
4. Position of the prism should not be disturbed for a given set of observations.

## SOURCES OF ERROR

1. If the three angles of refraction between adjacent pairs of faces are not equal, then  $A + \delta \neq i + e$ .
2. There may be an error in measuring the values of the angles.

## DISCUSSION

1. It is suggested that the value of angle of incidence be taken more than  $35^\circ$ . This is required for angles less than  $35^\circ$  as there is a possibility of total internal reflection inside the prism.
2. You must check your readings by applying the formula  $i + e = A + \delta$ .
3. The  $i - \delta$  curve that is obtained in this experiment is a non-linear curve. In such situations, more readings should be taken in the minimum deviation region to be able to obtain the value of angle of minimum deviation accurately. For example, if  $\delta$  readings are taken initially at  $35^\circ$ ,  $40^\circ$ ,  $45^\circ$  and  $50^\circ$  and if the  $i - \delta$  data points are situated as shown in Fig. E 13.3 then a few more readings need to be taken for values of  $i$  in the range  $45^\circ$  to  $55^\circ$  say, at a difference of  $1^\circ$  or  $2^\circ$ .

Taking more readings in this region will help in drawing a smooth curve. This will enable you to locate the position of the lowest point on the graph more accurately.

4. In the condition of minimum deviation, the refracted ray inside the prism becomes parallel to its base so as to satisfy the condition  $r = r'$ .
5. The graph does not show a sharp minimum. We have same deviation for a range of angle of incidence near minimum deviation. Therefore extra care should be taken in drawing tangential line to the  $i - \delta$  graph at minimum deviation.

## SELF ASSESSMENT

1. Interpret the graph between  $i$  and  $\delta$ .
2. If the experiment is performed with angle of emergence taken as angle of incidence, will there be any change in the  $\delta$  values? If yes, why? If not, why not?
3. What will happen if you go on decreasing the angle of incidence? If you think there is a minimum, try to find its expression theoretically. What happens when  $i$  is less than the minimum angle of incidence?

## SUGGESTED ADDITIONAL EXPERIMENTS/ACTIVITIES

1. Use the following equation to calculate refractive index of the material of the prism from the measured value of the angle  $A$  and  $\delta_m$  determined from the graph.

$$n = \frac{\sin i}{\sin r} = \frac{\sin [(A + \delta_m)/2]}{\sin(A/2)}$$

2. Measure the angle of emergence  $e$  corresponding to the value of each angle of incidence  $i$  and angle of deviation  $\delta$  you have observed. Compute the values of  $(i + e)$  and  $(A + \delta)$  and see how they compare.
3. Draw parallel horizontal lines cutting the  $i - \delta$  curve, you have drawn, at various values of  $i$  and  $e$ . Find out the mid points of these horizontal lines and join these mid points. What is the shape of the curve so obtained? If you find that this shape resembles that of a straight line, find its (i) slope (ii) y-intercept and (iii) x-intercept.
4. Determine the refractive index of different liquids using a hollow prism by plotting  $i - \delta$  graph.
5. Measure  $r$  and  $r'$  and  $e$  from the figures you have drawn. Find the refractive index of the material of the prism from the values of  $i$  and  $r$  and  $e$  and  $r'$ .